

### APPLICATION NOTE #27A

## Importance of Mismatch Tolerance for Amplifiers Used in Susceptibility Testing

By: Pat Malloy, Sr. Applications Engineer & Jason Smith, Supervisor Applications Engineering

RF amplifiers have a nominal output impedance of 50  $\Omega$  and ideally would only be used in applications where the load impedance is also 50  $\Omega$ . This ideal situation results in maximum power transfer from the amplifier to the load. 100% of the power is absorbed in the load with 0% power reflected back to the amplifier. Unfortunately, broadband RF amplifiers are used in “real life” applications that are characterized by load impedances other than 50  $\Omega$ . In fact, encountering a pure 50  $\Omega$  load is indeed rare. Not only is load mismatch common in most applications, but since load impedance and to a lesser extent amplifier output impedance vary with frequency, the extent of mismatch will also vary widely over the test frequency range. Susceptibility testing is just one such application where load mismatch can be extreme. This application note will focus on the often overlooked issue of mismatch in RF systems, the harmful effects of even a modest amount of mismatch and finally, how proper selection of the system amplifier can mitigate the ill effects of mismatch. Functioning as a key element in an EMC susceptibility system, the RF amplifier must be capable of dealing with extreme mismatches without compromising performance or reliability.

**Mismatch-** The condition whereby the output impedance of the RF source differs from that of the load is said to be a “mismatch”. The extent of mismatch can be characterized in terms of Voltage Standing Wave Ratio (VSWR). (See Annex A for VSWR formulas) In its simplest form, VSWR is seen as the ratio of the source output impedance (amplifier output) to the load impedance at a given frequency. For our purposes we will assume a nominal amplifier output impedance of 50  $\Omega$ . If the amplifier is driving an ideal load impedance of 50  $\Omega$ , the VSWR is 1:1 and there is no mismatch. This ideal condition results in maximum power transfer and zero power reflection. Real life applications are rarely characterized by 50  $\Omega$  loads and the resultant VSWR is greater than 1:1. In this typical situation, power is reflected from the load back into the source, or amplifier. The amplifier must be designed to routinely sink this reflected power without adversely affecting performance or reliability.

| Load VSWR   | dB mismatch loss at load | % Power reflected back to source |
|-------------|--------------------------|----------------------------------|
| 1:1         | 0                        | 0%                               |
| 1.5:1       | 0.18                     | 4%                               |
| 2:1         | 0.51                     | 11%                              |
| 3:1         | 1.25                     | 25%                              |
| 4:1         | 1.94                     | 36%                              |
| 5:1         | 2.55                     | 44%                              |
| 6:1         | 3.10                     | 51%                              |
| 10:1        | 4.81                     | 67%                              |
| $\infty$ :1 | $\infty$                 | 100%                             |

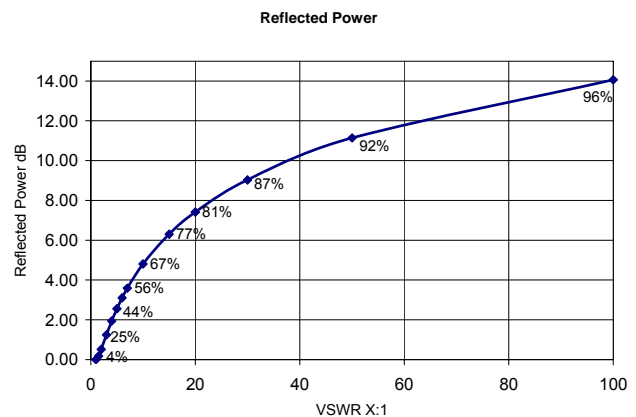

Figure 1: Power delivered to the load and reflected back to the source as a function of VSWR

Example: Let’s look at a typical situation where an amplifier with a 50  $\Omega$  output is driving a fairly decent antenna with a VSWR of 2:1. It can be seen from the formulas in Annex A that for this VSWR, the load could either be 100  $\Omega$  or 25  $\Omega$ . From the VSWR equations, 11% of the forward

power will be reflected while only 89% will be absorbed in the load. The table and graph in Figure 1 illustrates the adverse effects of mismatch on the power available at the load.

The obvious solution to avoid mismatch issues would be to utilize broad band matching networks to insure the output impedance of the amplifier is identical to the load. This might be theoretically possible, but in reality the output of the amplifier as well as the load impedance varies as a function of frequency. Furthermore, while we will restrict ourselves to discussing resistive loads in this application note for simplicity, actual loads are complex impedances consisting of resistive and reactive elements. While impedance transformers can be designed for specific impedances and narrow frequency ranges, a universal matching network covering the broad frequency ranges offered by modern amplifiers is virtually impossible to design. Even if it were available, it most likely would introduce an unacceptable level of insertion loss. Impedance transformers can be designed and are available for narrow frequency ranges as found in the 800A3 amplifier.

### Consider the effects of mismatch in an actual application...EMC susceptibility testing

Susceptibility testing covers extreme frequency ranges and uses broadband loads such as Bulk Current Injection (BCI) probes, transmission lines, biconical, log periodic, and horn antennas. While designers strive to hold the impedance of all these RF devices to 50  $\Omega$ , it is all but impossible. A perusal of the salient data sheets show a typical VSWR range of 1.5:1 for some log periodic antennas to a maximum of 100:1 for a biconical antenna operated at 20 MHz. To complicate matters, simple devices like cables and connectors contribute to the overall system mismatch since they are not a perfect 50  $\Omega$  across the broad frequency range required for susceptibility testing. A short or open, however brief, constitutes an infinite VSWR and 100% of the power is reflected back to the amplifier. It is essential that the RF amplifier be capable of absorbing reflected power from extreme mismatches encountered in normal EMC test applications. The amplifier must not only be capable of providing the necessary power, but it must be rugged and reliable.

### System Durability

Figure 1 demonstrates the exponential rise in reflected power as a function of VSWR. Even a relatively small system VSWR of 2:1 may be cause for concern. Certainly, more typical values ranging from 2:1 to 10:1 result in sufficient reflected power to cause damage to an amplifier that has not been designed to tolerate this amount of reflected power. Amplifiers that are unable to sink large amounts of reflected power require protection. One brute force approach is to simply attach an attenuator at the output of the amplifier. This technique is described in IEC 61000-4-6 where an optional 6 dB pad is inserted between the amplifier and the load. By doing so, the poor load VSWR is improved and the resulting reflected power is reduced. Not only is there less reflected power, but any reflected power is reduced by 6 dB by the attenuator, further protecting the amplifier. While initially this approach sounds plausible, the downside is that the forward power into the load is also attenuated by 6 dB. In this example, the original amplifier would have to be replaced by one 4 times the size. Fortunately, rugged amplifiers have been designed with this application in mind and can withstand this severe amount of reflected power.

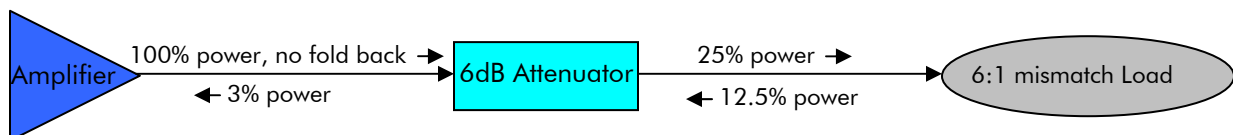

A large assortment of RF amplifiers are available which address a variety of testing needs across a vast array of applications. With so many choices, the challenge is to select the correct amplifier to accommodate unique application specific requirements. For example, while a small, light weight inexpensive amplifier may seem appropriate, when the characteristics of the application are considered, it may prove totally inadequate. To preclude such errors, an intimate knowledge

of amplifier specs and system requirements is required. Let's start by reviewing the salient characteristics of the two major types of RF amplifiers used for susceptibility testing...Class A and Class AB.

Table 1: Class A vs. Class AB Amplifier Comparison

| Characteristic                  | Class A Amplifier  | Class AB Amplifier   |
|---------------------------------|--|--|
| Output distortion               | Low distortion, highest Linearity                        | Higher distortion, poor Linearity                                      |
| Bias Scheme                     | Output current flows for 360 degrees of the input signal | Output current fall somewhere between 360 and 180 degrees of the input |
| AC power to RF power efficiency | Less Efficient   | More Efficient   |
| Construction                    | More components required to share the load               | Less components required to share the load                             |
| Size/Weight                     | Larger/Heavier   | Smaller/Lighter  |

While the above table highlights some of the basic differences between these amplifier types, the major characteristic that sets them apart is their ability to deal with reflected power resulting from mismatch.

Since class AB amplifiers are inherently unable to absorb reflected power, let's consider their use first. One of the following protection techniques must be used to protect the output stages from reflected power:

1. Continuously monitor the internal temperature of the amplifier. When the temperature exceeds a predetermined safe level, immediately shut down the amplifier.
2. Directly monitor the reflected power and when a dangerous threshold is hit, shut down the amplifier.
3. Monitor the reflected power and adjust the gain of the amplifier or reduce the drive level as the reflected power increases. This approach is often called "foldback" and is used to insure that the reflected power never exceeds the maximum allowable level.

The first and second approaches are best described as "brute force" efforts since they will shut down the test each time an inevitable mismatch occurs. Not only is the test terminated, there is no apparent means to proceed. Since a "real life" load can not be swapped out with one approaching an ideal 50 Ω, and broadband impedance matching is out of the question, the only practical recourse would be to add a 6 dB attenuator. The load VSWR is reduced and the reflected power is attenuated by the 6 dB pad. Unfortunately, as noted previously, this "fix" requires that the amplifier be resized to 4X the original size, which is a hefty penalty to pay.

Of the three approaches, the "foldback" scheme is most common. Figure 2 shows a typical Class AB output power vs. load VSWR curve taken from manufacturers published literature. This curve shows an alarming inability of the RF devices to sink even a minimal amount of reflected power. The amplifier must implement a "foldback" of the available RF output

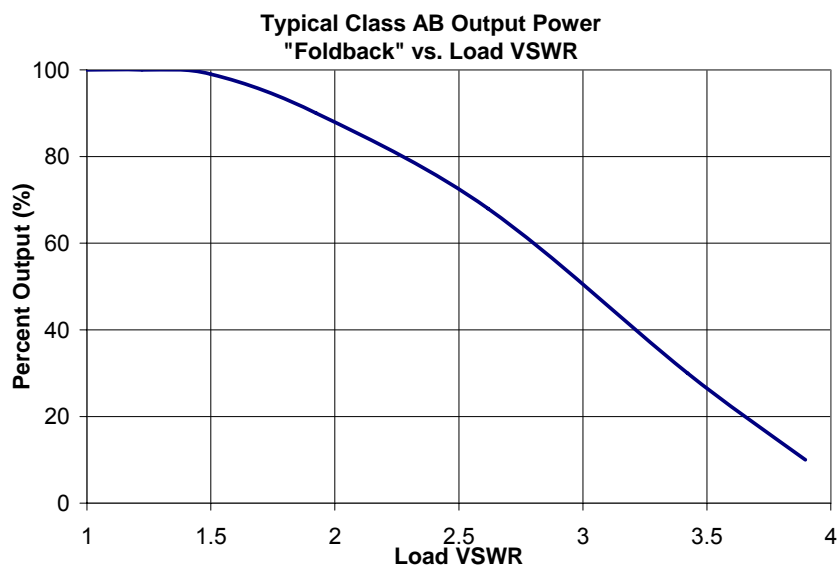

Figure 2: Manufacturer's data for Class AB "foldback"

power in an effort to protect its output stages. Specifically, the curve clearly shows that a 100 watt amplifier could not even sustain 100 watts into a modest typical antenna VSWR of 2.0:1. It reduces its output power to 89 watts. Thus, with as little as 11% of the output power reflected, the forward power has dropped to 89 watts. Considering a minimal increase in VSWR to a value of 3:1 and with only 25% of the output power reflected back, the Class AB amplifier has cut back its forward power to a meager 50 watts. This is clearly not the kind of performance needed in a susceptibility test system which must maintain prescribed field levels in spite of VSWR variations.

Any of the above three scenarios will protect the amplifier to some extent. However, there are situations where the amplifier is unable to react quickly enough or the reflection is of such a magnitude that complete protection is impossible. In these situations the amplifier is weakened or damaged. An extreme case occurs when a defective cable or load shorts or opens resulting in an infinite VSWR. As a result, 100% of the forward power is reflected back into the output stages of the amplifier. This occurrence is not as rare as one may think. The simple mistake of not thoroughly checking the integrity of all RF cables and connectors before running a test can cause such a catastrophic result.

For EMC susceptibility testing, it can be seen that the size, weight, and efficiency advantages of Class AB amplifiers are irrelevant if they are unable to handle reflected power. If class AB amplifiers can't do the job, what about class A amplifiers?

In Class A operation, the active devices are biased to insure that output current flows for 360 degrees of input signal. As noted above, this biasing technique results in excellent linearity and low distortion. An additional characteristic is that a properly designed Class A amplifier dissipates maximum power in its quiescent state and must be built to handle a great deal of power dissipation. Contrasted to a Class AB amplifier, the Class A design necessarily requires the use of larger active devices, and quite often, a larger number of devices to share the heat dissipation. Furthermore, additional attention is paid to heat sinking, cooling considerations, and rugged component selection. When an input signal is applied and RF power is dissipated into a load, the RF devices actually run cooler. Since they are thus operating below their normal operating temperature, power reflections resulting from operating into high levels of VSWR are not a problem.

While Class A amplifiers are clearly superior to Class AB amplifiers for immunity testing, as it turns out, not all Class A amplifiers are made alike. Some Class A amplifiers are not designed to handle extreme mismatches and may fail instantly or may weaken over time with everyday use. In some cases, Class A amplifiers must institute the same protection features found on a Class AB amplifier. While all Class A amplifiers generally tolerate reflected power better than Class AB amplifiers, some can be damaged by the severe reflected power that occurs when the occasional short or open is encountered while conducting an EMC test. Unfortunately, this is not all that uncommon in busy EMC test facilities, especially when tests are running behind schedule and the pressure is on.

### **AR RF/Microwave Instrumentation's Approach**

AR has taken a ruggedized approach to the design and implementation of amplifiers. From the very first amplifier developed to the extensive line of amplifiers offered today, we have understood the extent of mismatch encountered by our customers and are devoted to delivering the maximum output power into any load, regardless of mismatch, without compromising the integrity of the amplifier. A statement of this commitment is found on our data sheets..."Will operate without damage or oscillation with any magnitude and phase of source and load impedance."

A summary of mismatch performance for typical Class A and AB amplifiers is shown in Figure 3. The 100 watt curve is representative of most amplifiers below 500 watts. It is clearly seen that the amplifier delivers a Minimum Available Power (MAP) of 100 watts irrespective of the load VSWR, including opens and shorts. As output power increases it becomes increasingly difficult to absorb 100% of the reflected power uniformly. Hot spots at these elevated power levels can cause damage or at least affect reliability. Nevertheless, AR high power amplifiers continue to offer 100% mismatch tolerance up to a load VSWR of 6:1. Once this level is reached, the output power is limited to 50% of rated power. For example, a 1000 watt amplifier will provide a MAP of 1000 watts up to a load VSWR of 6:1. At this point approximately 500 watts is reflected. From this point on, as load VSWR increases the output power is gradually reduced until it reaches 500 watts for an infinite load VSWR. Figure 3 clearly shows the advantage of this implementation when compared to the conventional "foldback" scheme used by typical Class AB amplifiers. In practice, the AR conservative VSWR compromise of 6:1 works well in that load VSWR is often held to this value or better. If it strays beyond, rest assured your AR amplifier has sensed the increase and has implemented sufficient limiting to protect the amplifier from any damage. See Annex B for a detailed case study of how Class A and Class AB amplifiers deal with mismatch.

Of course adding these advanced features to our amplifiers does affect the size, considering the fact that additional oversized active components as well as additional heat sinks and cooling schemes are required. There is also some impact on the initial cost. Nevertheless, we feel that in the final analysis, the need to deliver the best, most rugged and reliable amplifier is of utmost importance. Our customers must have confidence that our products perform to spec when they are needed and maintain output power irrespective of mismatch. This is an absolute requirement!

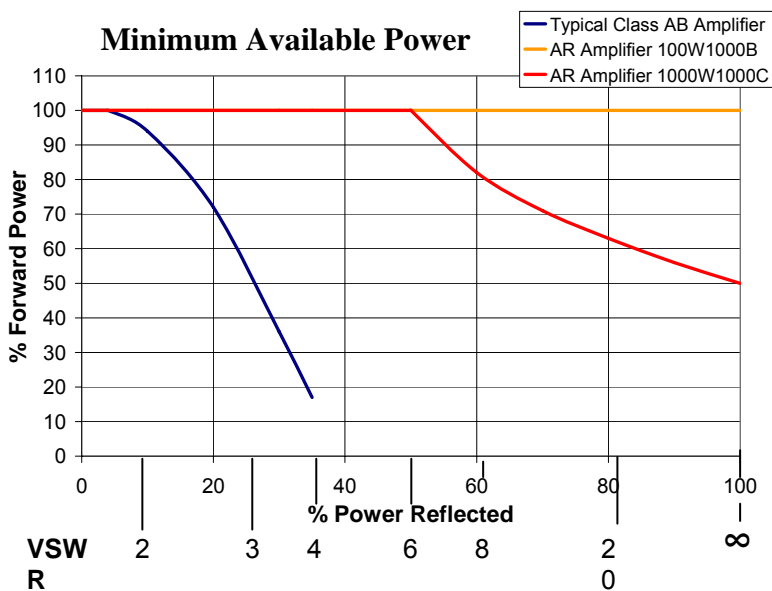

Figure 3

## Annex A

### VSWR Calculations:

$vswr$  = Voltage Standing Wave Ratio, P=Power (watts), Z=Impedance (ohms)

$$vswr = \frac{1 + \sqrt{\frac{P_{Rev}}{P_{Fwd}}}}{1 - \sqrt{\frac{P_{Rev}}{P_{Fwd}}}}, \quad vswr = \frac{1 + \rho}{1 - \rho}, \quad vswr = \frac{Z_L}{Z_o}, \quad vswr = \frac{Z_o}{Z_L}$$

$\rho$  = Reflection Coefficient

$$\rho = \left| \frac{Z_1 - Z_2}{Z_1 + Z_2} \right|, \quad \rho = \sqrt{\frac{P_{Rev}}{P_{Fwd}}}$$

$RL(dB)$  = Return Loss

$$RL(dB) = -20 \log(\rho), \quad RL(dB) = 10 \log\left(\frac{P_{Fwr}}{P_{Rev}}\right), \quad RL(dB) = -20 \log\left(\frac{vswr - 1}{vswr + 1}\right)$$

$ML(dB)$  = Mismatch loss

$$ML(dB) = 10 \log\left(\frac{P_{Fwr}}{P_{Fwr} - P_{Rev}}\right), \quad ML(dB) = -10 \log(1 - \rho^2),$$

$$ML(dB) = -10 \log\left(1 - \left(\frac{vswr - 1}{vswr + 1}\right)^2\right)$$

AR Class A Amplifier vs. Typical Class AB Amplifier Power Absorbed by the Load

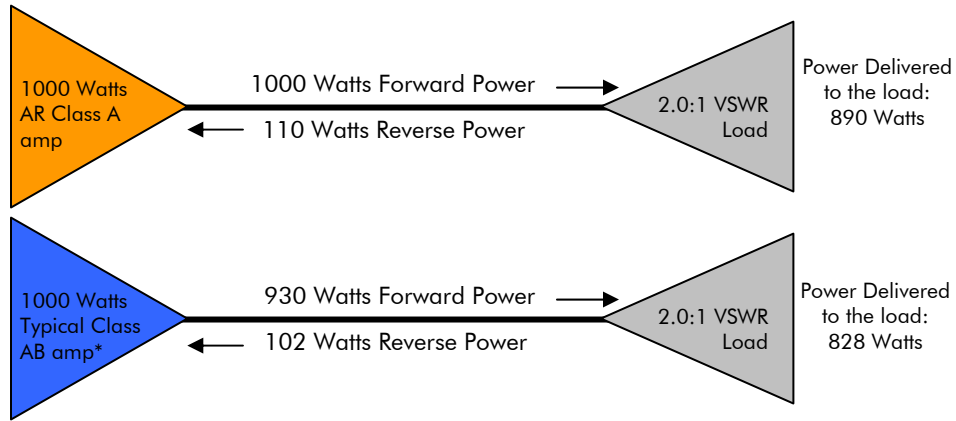

In the above example, the Class A amplifier is able to provide full rated output to the load. Since 110 watts is reflected back into the output part, 890 watts is actually dissipated in the load. The Class AB amplifier has already employed foldback protection therefore limiting its output power to approximately 930 watts. Since 11% of the forward power is reflected back to the amplifier, only 828 watts is dissipated in the load.

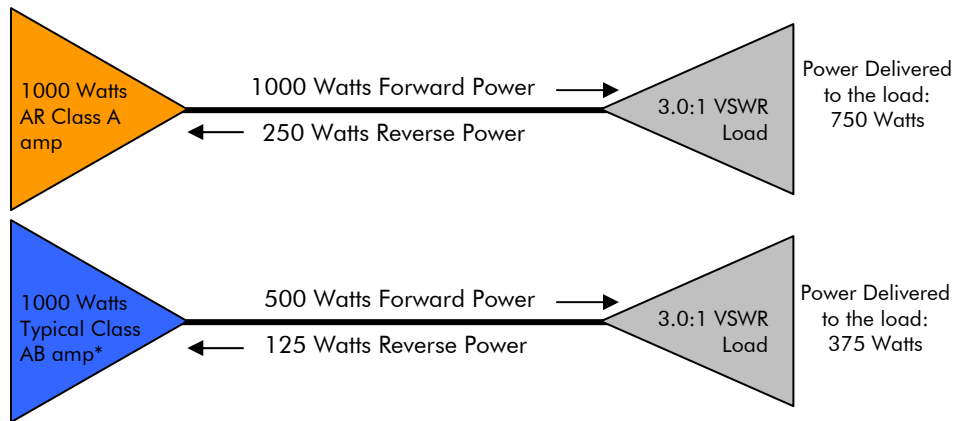

In the above example, the Class A amplifier is able to provide full rated output to the load. Since 250 watts is reflected back into the output part, 750 watts is actually dissipated in the load. The Class AB amplifier has already employed foldback protection therefore limiting its output power to approximately 500 watts. Since 25% of the forward power is reflected back to the amplifier, only 375 watts is dissipated in the load.

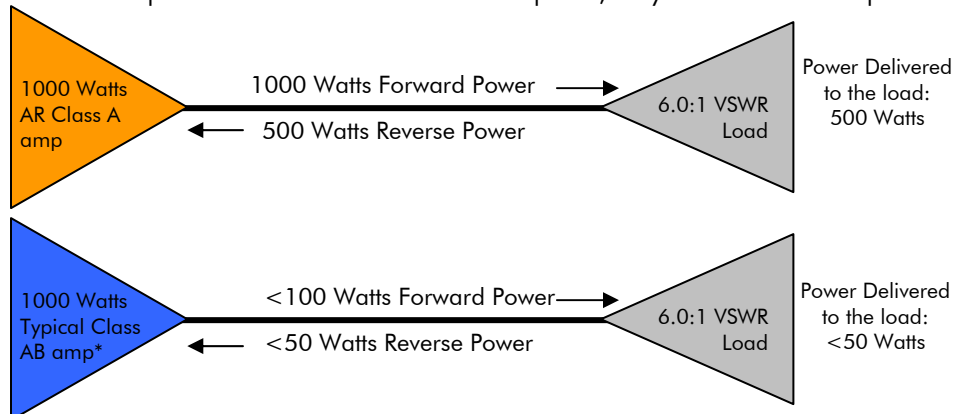

In the above example, the Class A amplifier is able to provide full rated output to the load. Since 500 watts is reflected back into the output part, 500 watts is actually dissipated in the load. The Class AB amplifier must employ even more foldback protection thus limiting its output power to less than 100 watts. Since 50% of the forward power is reflected back to the amplifier, less than 50 watts is dissipated in the load.

\*Also representative of less capable Class A amplifiers.